

Use VMware vSAN HCI Mesh to manage your vSAN storage resources and share them across server clusters

We set up vSAN HCI Mesh on Dell EMC PowerEdge MX hardware and used the technology to improve hyperconverged resource flexibility



Dell EMC™ PowerEdge™ MX is a modular platform that can accommodate a number of compute nodes with local storage drives. In our past studies with PowerEdge MX, we found the platform easy to manage and quick to get started with.^{1,2}

With VMware® vSAN™ HCI Mesh, the PowerEdge MX platform can share vSAN storage resources with compute nodes outside of a specific cluster. This new feature also allows customers to independently scale compute and storage resources while maintaining the management and operational simplicity of HCI.

To learn more about using PowerEdge servers with VMware technology, visit <https://www.delltechnologies.com/en-us/solutions/vmware/servers-for-vmware.htm>.

How vSAN HCI Mesh works with your data center hardware

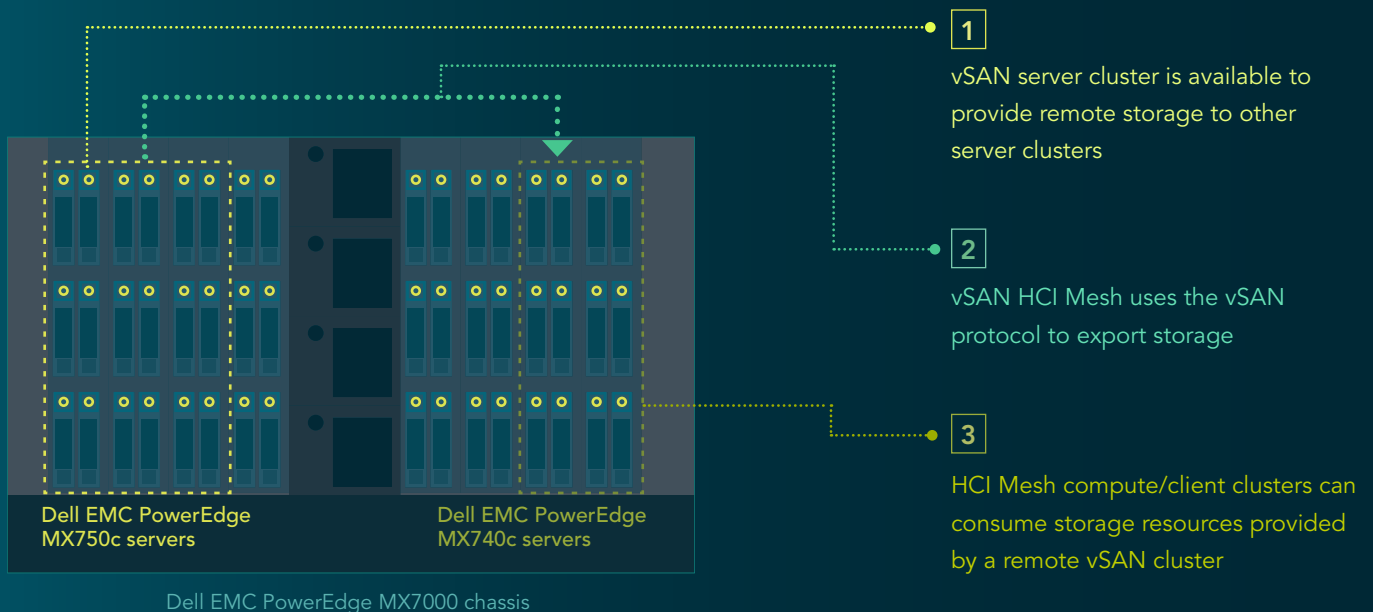

About vSAN HCI Mesh

Before vSAN HCI Mesh, adding resources to a hyperconverged cluster meant dedicating resources to that cluster specifically. But with VMware vSAN version 7.0, update 2, IT staff are now able to join together multiple independent server clusters to create mesh-like architecture where resources are disaggregated and freely shareable.³

Benefits of vSAN HCI Mesh

- Freely share vSAN HCI cluster resources
- Use both vSAN HCI Mesh and external storage
- Deploy multiple datastores with different storage classes
- Manage resources via the familiar VMware vSphere® web client

Learn more at <http://facts.pt/FGiJdQ8>



1 "Add next-generation Dell EMC PowerEdge MX servers to your VMware Cloud Foundation infrastructure with ease," accessed April 19, 2021, <https://www.principledtechnologies.com/Dell/PowerEdge-MX-deployment-process-0421.pdf>.

2 "Maximize time savings for your IT admins with the Dell EMC PowerEdge MX platform and OpenManage Enterprise," accessed April 19, 2021, <https://www.principledtechnologies.com/Dell/PowerEdge-MX-HPE-Synergy-Cisco-UCS-0319.pdf>.

3 John Nicholson, "Introducing VMware vSAN HCI Mesh," accessed April 19, 2021, <https://blogs.vmware.com/virtualblocks/2020/09/16/introducing-vmware-vsan-hci-mesh/>.